



- § Control unit for traffic light systems according to DIN EN 12675
- § Electronic and traffic safety according to DIN VDE 0100 and DIN VDE 0832-100
- § 19" case according to IEC 60297-3-101
- § For centralized and decentralized structures
- § Hinged operational panel provides easy access to the internal computer module deTRAcon
- § Emergency switch ( $I_N \leq 10A$ ) for switching off the signal heads
- § Electromagnetic compatibility according to DIN EN 50293



### Technical data

<b>Case</b>	Dimensions: 84HP x 3HU x 250 mm Weight: approx. 6.5 kg
<b>Operating temperature</b>	- 25°C ... + 60°C without condensation
<b>Storage temperature</b>	- 25°C ... + 85°C
<b>IP protection</b>	IP00
<b>Operating voltage</b>	230 VAC / 50Hz
<b>Fuses</b>	2 x LS 16B
<b>Standards</b>	DIN VDE 0832 (Feb. 2002) DIN EN 12675 (Dec. 2000) DIN VDE 0100 TL- <i>Transportable Lichtsignalanlagen</i> (Portable traffic light systems) 97 RiLSA Cologne 1996, with partial continuation 2003 max. 30
<b>Switch cards</b>	
<b><u>Terminal deTRAterm</u></b>	
<b>Display</b>	4x20 signs, STN (yellow-green) Transreflective
<b>Keyboard</b>	Membrane keyboard, 18 keys
<b><u>Features</u></b>	
<b>Topology</b>	Centralized or decentralized structure of signal head switches, combination possible
<b>Fieldbus</b>	2 separate fieldbus traces CAN bus 100 kb/s, V2.0 part B (active), galvanically isolated, terminating resistor on last CAN node
<b>Max. number of CAN nodes</b>	30 (up to max. 90 signal heads)
<b>Maximal length of one bus</b>	500 m

### Technical data





- Supervising**
  - Supervising of lamps according to DIN VDE 0832 (Feb. 2002)
  - CRC check of the entire FLASH during operation
  - Check of the current signal aspect
    - § Supervising of the external lamp switches
    - § Supervising of bus
    - § Reaction time  $\leq 200$  ms
    - § 2 Hardware watchdogs + software watchdog
- Control computer**
  - § deTRAcon
  - § deTRApdex (optional)
- Log**
  - Logs can be retrieved using the terminal and the data supply interface
- Software**
  - § Creation of supply data with deTRAver
  - § Simulation on PC with deTRASim

### Block diagram

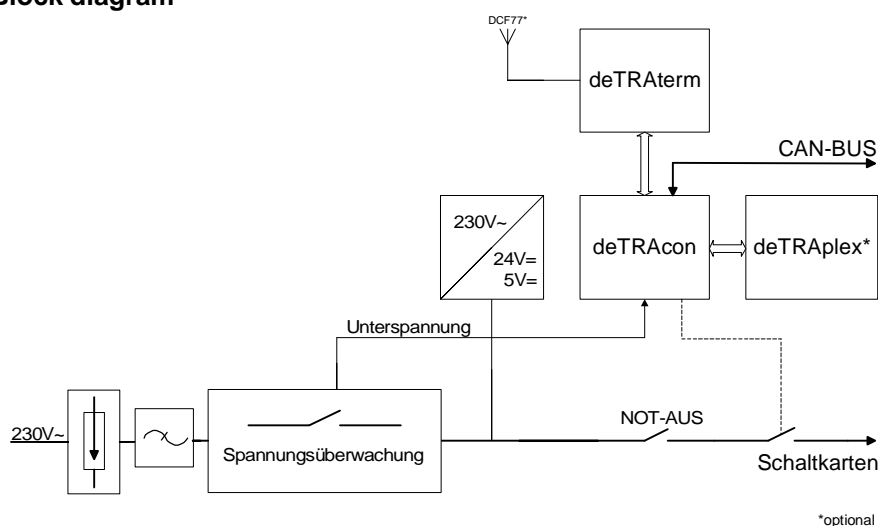

### Control computer deTRAcon:

- § Supervises the status of all connected cards and checks the current signal aspect.
- § The module has interfaces for data supply, service and for connecting an operation terminal.
- § For larger systems and more complex control tasks, the control unit receives signal aspects from a second deTRApdex control computer.

### deTRApdex control computer with extended functionality:

- § Handles complex control processes for TLS control
- § Necessary for utilizing the VS-PLUS core (Verkehrs-Systeme AG)
- § Upgradeable past events memory on CompactFlash memory card
- § Interfaces to traffic computer, loop detectors and internet protocols
- § OCIT-Outstations interface
- § Sends signal aspects to the control computer deTRAcon

### Scope of delivery

Control unit (Article no. 102)

### Accessories

Control computer deTRApdex (Article no. 108)

- technical information subject to change without notice -

Scope of  
delivery

Accessories





# deTRA 3000 Control unit

## Datasheet

Page 3 of 3  
March 20, 2008  
Art. no. 102

---

dresden elektronik  
verkehrstechnik gmbh

[www.dresden-elektronik.de](http://www.dresden-elektronik.de)

**Contact**



Enno-Heidebroek-Str. 12  
D-01237 Dresden

E-Mail: [info@dresden-elektronik.de](mailto:info@dresden-elektronik.de)  
Phone: +49 351 – 31 85 0-0 Fax: -10